



# 6795-C

## FROZEN BEVERAGE FREEZER

Two flavor, Floor, Gravity feed

### Powerful & Versatile

High capacity two flavor floor model for frozen beverage and milkshakes

#### Fast Freeze Down

Patented high efficiency heat exchanger allows fast freeze down with low energy consumption

#### Simple Control, Easy Operation

Simple and intuitive control system makes operation and viscosity adjustment easy, swift and more precise

#### Low Mix Indicator

Light turns "ON" at low mix to alert operator to add mix

#### See-through Dispensing Door

Clear dispensing door design makes product more attractive and serves as great marketing tool

#### Standby & Indicator

Maintains product temperature in both mix hopper and freezing cylinder below 4.4°C (40°F) overnight; Indicator lights up during Standby

Higher capacity solution with greater flexibility to serve larger crowds alcoholic & non-alcoholic frozen drinks including milkshakes



### Hopper Agitators

Maintain product consistency and prevent product separation

### Self-closing Dispensing Valves

Automatically prevents product overflow after dispense

### Safety Protections

- High pressure switch to prevent compressor overheating
- Thermal overload to protect from motor overheating

### Light Box (Optional)

- Illuminates flavor cards to attract more business
- Changes color to indicate Low Mix and Standby

### One-hand Operated Spinner (Optional)

- Adds ability to blend and offer more varieties of treats
- Allows for multi-tasking one-hand operation that helps increase productivity and reduce serving time



# 6795-C

## FROZEN BEVERAGE FREEZER

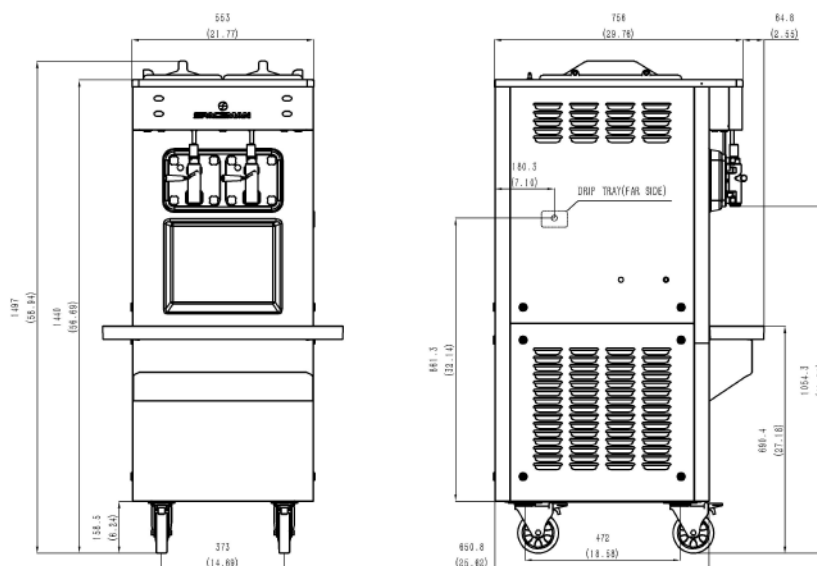

### SPECIFICATIONS

|                            |                  |
|----------------------------|------------------|
| Flavors                    | 2                |
| Freezing Cylinders         | 2 x 6.9L / 7.3qt |
| Mix Hoppers                | 2 x 12L / 12.7qt |
| Output Capacity (80 grams) | 480 serves/hr    |
| Clearance Requirements     | 152mm/6" on back |

### Weight Kg/lb

|          |                      |
|----------|----------------------|
| Net      | 250 / 556            |
| Shipping | 270 / 600            |
| Volume   | 1.12 CBM / 39.63 CBF |

### Dimensions Net (mm/in) Shipping (mm/in)

|        |             |             |
|--------|-------------|-------------|
| Width  | 553 / 21.8  | 720 / 28.3  |
| Depth  | 651 / 25.6  | 940 / 37.0  |
| Height | 1497 / 58.9 | 1660 / 65.4 |

### Electrical MFS MCA Power(kW)

|              |    |    |     |
|--------------|----|----|-----|
| 220-240/50/1 | 30 | 21 | 3.6 |
| 208-230/60/1 | 30 | 24 | 4.0 |

### FEATURES

|                                |                 |
|--------------------------------|-----------------|
| Control Systems                | Two, Mechanical |
| Refrigerated Hoppers           | ✓               |
| Hopper Agitators               | ✓               |
| Standby Mode                   | ✓               |
| Auto Closing Dispensing Valves | ✓               |
| Low Mix Indicator Light        | ✓               |
| Low Mix Indicator Alarm        | ✓               |
| Standby Mode                   | ✓               |
| Standby Indicator Light        | ✓               |
| High Pressure Protection       | ✓               |
| Thermal Overload Protection    | ✓               |

### AVAILABLE OPTIONS

|                         |   |
|-------------------------|---|
| Top Air Discharge Chute | ✓ |
| Spinner                 | ✓ |
| Light Box               | ✓ |

• Above specifications are subject to change without notice